

## Supplementary instructions L-BV2, L-BV5

Supplement to instruction manual 610.44440.40.000

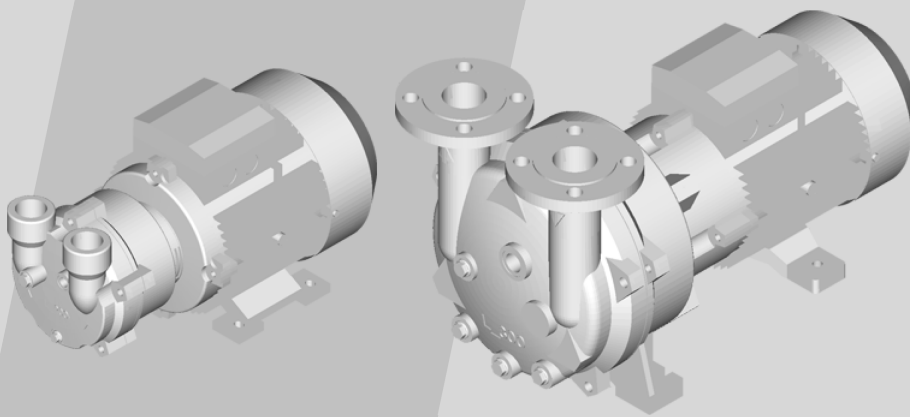

Devices of group II, category 2G



**2BV2060**  
**2BV2061**  
**2BV2070**  
**2BV2071**  
**2BV5110**  
**2BV5111**  
**2BV5121**  
**2BV5131**  
**2BV5161**



**L-Serie**  
**L-Series**

**Flüssig-  
keitsring**  
**Liquid Ring**



**Content**

Concerning 1 Safety .....2  
    Concerning 1.2 General safety instructions.2  
Concerning 2 Correct use of the equipment ....3  
Concerning 3 Technical Data .....5  
    Concerning 3.3 Operating conditions,  
    normal operation.....5  
Concerning 5 Installation.....5  
    Concerning 5.1 Installing the unit .....5  
    Concerning 5.2 Connecting the unit  
    mechanically.....5  
        Concerning 5.2.1 Connecting the suction  
        and discharge branches .....5  
        Concerning 5.2.3 Connecting up system  
        components.....5  
        Concerning 5.2.4 Ancillaries .....8  
    Concerning 5.3 Connecting the motor  
    electrically.....8  
        Concerning 5.3.2 Operating with a  
        frequency converter.....8  
Concerning 7 Operation .....8  
Concerning 9 Maintenance .....8  
    Concerning 9.1 Servicing.....8  
EU Declaration of conformity.....9

**Concerning 1 Safety**

**Concerning 1.2 General safety instructions**

**⚠ WARNING**  
The respective national accident prevention regulations must be complied with!

**⚠ WARNING**  
**Improper handling of the system can result in serious or even fatal injuries!**  
Operating manual 610.44440.40.000 as well as this supplementary operating manual:

- must be read and understood before commencing any work on or with the unit,
- must be strictly adhered to.
- must be available where the unit is used.

**⚠ WARNING**  
**Improper handling of the system can result in serious or even fatal injuries!**  
All work on and with the system (transport, installation, commissioning, decommissioning, maintenance, disposal) may only be carried out by trained and reliable skilled staff!

## Concerning 2 Correct use of the equipment

Point 2 "Intended Use" from 610.44440.40.000 is replaced by:

### This operating manual

- is applicable to L-Series Liquid ring vacuum pumps / compressors (units):  
series L-BV2, L-BV5  
types 2BV2060 2BV2061 2BV2070  
2BV2071 2BV5110 2BV5111  
2BV5121 2BV5131 2BV5161
- Additional instructions Concerning explosion protection according to Guideline 94/9/EC and 2014/34/EU
- contains instructions for the unit's transportation, installation, start-up, operation, shut-down, storage, maintenance and disposal,
  - must have been read and properly understood by operating and maintenance staff before beginning any work with or on the unit.
  - must be complied with and
  - must be at hand where the unit is installed.

### Operating and maintenance personnel

Operating and maintenance personnel for L-BV2, L-BV5 units must be trained and authorised for the work to be carried out.

Work on electrical installations may only be carried out by an electrician specialist. An electrician specialist is someone who can evaluate and identify potential risks for the assigned task as a result of their technical training, knowledge and experience as well as knowledge about relevant regulations.

### L-BV2, L-BV5 units

- create a vacuum or overpressure.
- are used to extract, deliver and compress the following gases / vapours:
  - all dry and damp gases which are not explosive, combustible, aggressive or poisonous,
  - air or air-vapour mixtures.
  - in the case of aggressive or poisonous gases / vapours, please consult the manufacturer.
  - the gases / vapours must be free of solid matter.  
Small quantities of light suspended matter or liquids can be conveyed along too.
- are suitable for a deep vacuum range.
- are equipped with RL 94/9/EC and 2014/34/EU three-phase drive motors. For more detailed information please consult the motor manufacturer's accompanying operating instructions.
- are available in two constructions:
  - Construction for normal requirements
  - Construction for higher corrosion-resistance and hygiene requirements (only 2BV2070, 2BV2071 and 2BV5..)
- are designed for industrial plants.
- are designed for continuous operation.

When operating the units, the limiting values listed in chapter 3 operating manual 610.44440.40.000 "Technical Data" are to be complied with.

### Scope of application for units according to Guideline 94/9/EC and 2014/34/EU

#### Inside area of explosion prevention design

L-BV2, L-BV5 units are suitable for conveying gases/vapours where a potentially explosive atmosphere is occasionally expected to be present.

This specification includes category 2G for the internal space of the units.

If the specified maximum temperatures are complied with, the units are suitable for temperature class T4.

#### Surrounding area

When rating the device category, both the place where it is installed and its internal space must be taken into consideration.

Installing L-BV2, L-BV5 units for category 2G is allowed for areas where potentially explosive gases / vapours are expected to occur occasionally.

If the specified maximum temperatures are complied with, the units are suitable for temperature class T3.

#### L-BV2, L-BV5 unit operating liquid

 <b>WARNING</b>
The ignition temperature of the operating fluid must be above 150°C [150.00°F]. The chosen operating liquid must comply with the requirements / properties stated below. It must not corrode or destroy the pump components used.

 <b>WARNING</b>
Monitoring of the operating liquid status before starting up as well as monitoring of trouble-free feeding of the operating liquid while in operation should be built into the system. The system must shut down if there is a failure in the operating fluid feed. Operating without operating fluid must be avoided under all circumstances.

<b>NOTE</b>
When using operating fluids with a heat capacity of < 3 kJ/kg K, or a boiling point which does not lie 20 K above the input temperature, consult the manufacturer.

#### Operating liquid type:

Normally use water with a pH-value between 6 and 9, or any other liquid compatible with the process.

It must be free of:

- Foreign matter and objects:
- Crystalline precipitate substances
- Substances which tend to stick or jam

No precipitate substances may be produced from the operating fluid during the sealing process. Likewise, no substances may be used which tend to polymerise of their own accord or when in contact with propellant gas.

Compatibility must be checked with regards to chemical reactions between the operating liquid and the slide ring seal, the operating fluid and other pump parts as well as the operating fluid and the propellant gas.

#### Foreseeable misuse

The following are forbidden:

- Use of the unit 2BV2060 2BV2061 2BV2070 2BV2071 2BV5110 2BV5111 2BV5121 2BV5131 2BV5161 in non-industrial plants, unless the necessary precautions and protective measures have been taken at the plant, e.g. protection against contact by children's' fingers.
- Setting up and use of units in zones 0, 20, 21 and 22.
- The extraction, transport and condensing of aggressive or poisonous media unless the units are specifically designed for such media.
- to evacuate, convey and compress explosive, inflammable, or aggressive mediums, which could damage the slide ring seal.
- To evacuate, convey and compress gases or gas mixtures which are explosive when air is not present, or may change the unit's safety-relevant material properties.
- Operation with a frequency converter.
- Operation of the unit at any values other than those specified in chapter 3 "Technical data" in the 610.44440.40.000 operating manual.

Modifications to the units are forbidden for safety reasons.

The operator is not allowed to carry out maintenance, servicing and repair work which requires the machine to be dismantled.

## Concerning 3 Technical Data

### Concerning 3.3 Operating conditions, normal operation

#### Temperatures

Temperature of the operating liquid	
[°C]	[°F]
max. +65	max. +149
min. +5	min. +41
Nominal value:	
+15	+59

#### Pressures

##### Minimum suction pressure of the gas

If an explosive gas mixture should arise due to ambient air entering the unit, the use of process gas must be ensured for the cavitation protection. If the unit suction pressure ( $p_{1 \text{ min}}$ ) doesn't stand at a minimum of 50 mbar above the vapour pressure ( $p_{\text{Vapour}}$ ) of the operating fluid ( $\Rightarrow p_{1 \text{ min}} \leq p_{\text{Vapour}} + 50 \text{ mbar}$ ) or when there are changes in the operating conditions (media, temperatures), consult the manufacturer.

## Concerning 5 Installation

### Concerning 5.1 Installing the unit

#### Conditions for setting up the system:

The type of protection on the drive motor must correspond to the ambient atmosphere requirements in accordance with guideline 94/9/EC and 2014/34/EU.

The equipment and components added to the unit must also correspond to the requirements for device group II category in guideline 94/9/EC and 2014/34/EU.

The equipment and components added to the unit must also correspond to the requirements for device group II category in guideline 94/9/EC and 2014/34/EU, unless they have their own ignition source. The bleeder resistance for each installed accessory or attached part as well as for the unit must have  $< 10^6 \text{ Ohm}$  to ground when assembled!

### Concerning 5.2 Connecting the unit mechanically

#### Concerning 5.2.1 Connecting the suction and discharge branches

In order to prevent overloading from throttle on the discharge side, pressure monitoring (G2, Fig. 1, page 6) must be installed on the other side of the unit's gas output flange. If the maximum outlet pressure  $p_{2 \text{ max}}$  specified in the 610.44440.40.000 operating manual section 3.3, "Operating conditions, normal operation" is exceeded, the equipment must switch off. If operating with cavitation protection, the line must have sufficient electrical conductivity (bleeder resistance  $< 10^6 \text{ } \Omega$ ).

Foreign bodies must be prevented from getting into the pump.

If there is danger of foreign bodies getting in while the pump is operating or switched off, suitable filters must be attached.

#### Concerning 5.2.3 Connecting up system components

The built-in monitoring systems must be fully functional independently from one another. The systems must also remain independent if computer-programmed controls are used.

#### Monitoring of continual operating liquid feed

Monitoring of continual operating liquid feed is compulsory. Monitoring can be ensured by the following alternative systems:

- Measuring the operating liquid volume flow (F1, Fig. 1, page 6) with suitable sensor and analysis device. Switching commands must operate directly on the switches. When using a volume flow device which can block, an additional redundant monitoring system must be provided. Specifications regarding failure safety as well as calibration and servicing intervals should be taken from the monitoring device operating manual.
 

**Disconnection condition:**  
Volume flow  $\leq 50 \%$  of the design operating fluid flow  
(see 610.44440.40.000 operating manual section 3.3, "Operating conditions, normal operation")

b) Operating fluid temperature measurement in the drain tapping (F2, Fig. 1, page 6), or on the unit housing (F5, Fig. 1, page 6) with suitable temperature sensor.

**Disconnection condition:**

Temperature  $\geq 60\text{ }^{\circ}\text{C}$  ( $140\text{ }^{\circ}\text{F}$ )

The measurement and control device must be suitable or certified to take reliable measurements for disconnection conditions and shut down the equipment if necessary.

The device must be certified with regard to its point of installation in accordance with its category.

It is recommendable to implement the monitoring systems in accordance with EN ISO 13849.

The volume flow measurement sensor must be suitable for the area prevailing in the measuring point internal space.

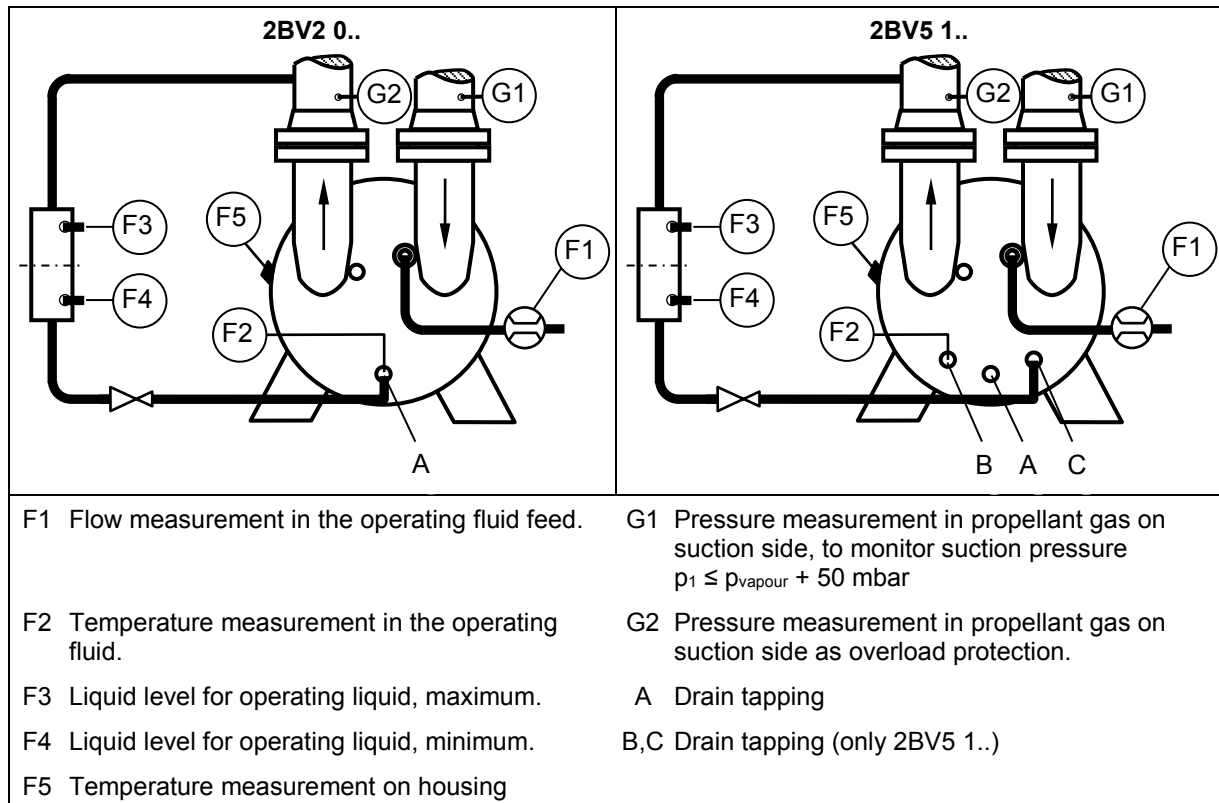

Fig. 1: Position of measuring points

**Monitoring liquid level before starting up**

Monitoring the liquid level before starting up is compulsory.

Monitoring can be ensured, for instance, by inductive proximity switches, solenoid-operated sensors, or pressure-dependent sensors, each combined with an analysis device.

The liquid level switches (F3, F4, Fig. 1, page 6) should be installed in the liquid level monitoring device (position Fig. 1 page 6).

The monitoring device sensors must be non-corrosive and certified for category 2 if there is direct contact with the internal space.

The measurement and control device must be suitable or certified to take reliable measurements for disconnection conditions and shut down the equipment if necessary.

The device must be certified with regard to its point of installation in accordance with its category.

It is recommendable to implement the monitoring systems in accordance with EN ISO 13849.

The liquid level monitoring sensor must be suitable for the area prevailing in the measuring point internal space.

It must only be possible to turn on the unit if the given fluid level stands between  $h_{f\text{ min}}$  and  $h_{f\text{ max}}$  (Fig. 2, page 7).

**NOTE**

The liquid level monitoring device (Fig. 1, page 6) is equipped with a shut-off valve which opens after the unit is switched off and closes again before starting up after the filling level has been regulated.

If a connection between the device and the ambient atmosphere is not possible, or undesirable, due to the type of media used, the line should be routed back into the equipment behind the shut-off valve on the suction side in a suitable way (Fig. 1, page 6).

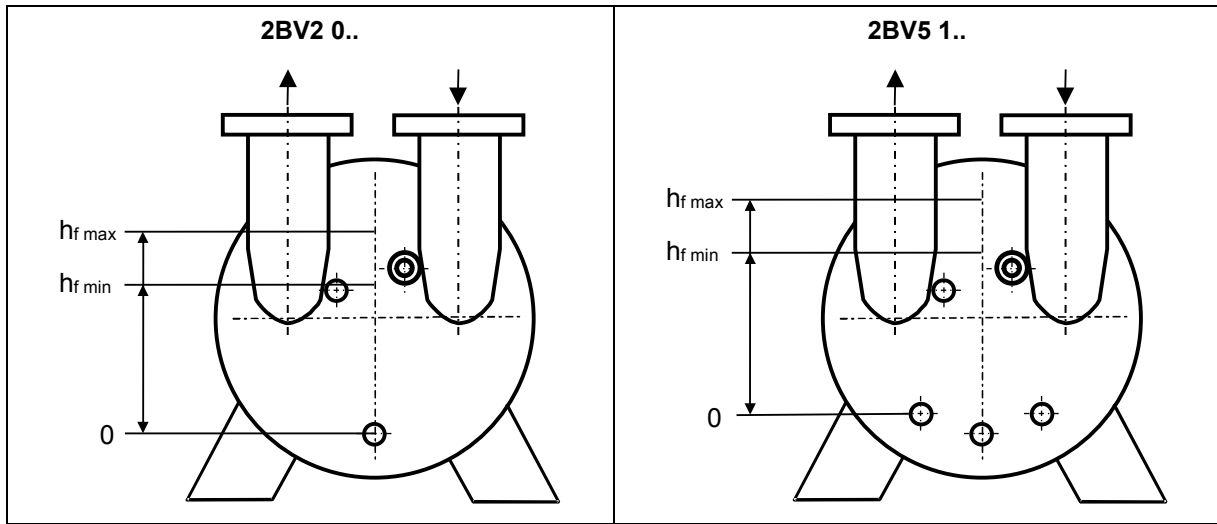

Type	Minimum $h_{f \min}$ [mm]	Maximum $h_{f \max}$ [mm]	Minimum $h_{f \min}$ [inches]	Maximum $h_{f \max}$ [inches]
2BV2060	75	95	2.95	3.74
2BV2061				
2BV2070	95	120	3.74	4.72
2BV2071				
2BV5110	116	156	4.57	6.14
2BV5111				
2BV5121	130	170	5.12	6.69
2BV5131	140	185	5.51	7.28
2BV5161	175	235	6.89	9.25

Fig. 2 Operating liquid level

**Concerning 5.2.4 Ancillaries**

**Operating fluid separator**

The 2BX1 102, 2BX2 103 und 2BX1 107 stainless steel separators do not come under guideline 94/9/EC and 2014/34/EU as they don't have their own ignition sources. The propellant gas and the operating fluid must not react chemically to the separator. The separator bleeder resistance must have <math> < 10^6 </math> Ohm to ground when attached or installed!

When a suction-side separator is used, only a pressure-resistant construction is permitted in accordance with guideline 97/23/EC. The standard separator as in the catalogue must not be used.

**Check valve**

The 2BY6 9-type metal check valves do not come under guideline 94/9/EC and 2014/34/EU as they don't have their own ignition sources. The propellant gas and the operating fluid must not react chemically to the check valve. The check valve bleeder resistance must have <math> < 10^6 </math> Ohm to ground when attached or installed!

**Gas ejector**

The 2BP5-type metal gas ejectors do not come under guideline 94/9/EC and 2014/34/EU as they don't have their own ignition sources. The propellant gas and the operating fluid must not react chemically to the gas ejector. The gas ejector bleeder resistance must have <math> < 10^6 </math> Ohm to ground when attached or installed! The gas propellant must be free of statically rechargeable particles.

**Concerning 9 Maintenance**

**Concerning 9.1 Servicing**

The operator is not allowed to carry out any kind of maintenance, servicing and repair work which requires the machine to be dismantled.

Interval	Maintenance procedure
weekly	Remove dust deposits from unit.
2 years or 18,000 operating hours	Ball bearings to be replaced or re-greased by service technician.

**Concerning 5.3 Connecting the motor electrically**

The accompanying drive motor operating manual must be strictly adhered to:

**Concerning 5.3.2 Operating with a frequency converter**

<b>⚠ WARNING</b>
Operating the unit with a converter is not permitted.

**Concerning 7 Operation**

<b>⚠ DANGER</b>
If the system is shut down by a monitoring system during operation, its cause must be identified and the problem must be rectified before restarting. Do not go below the safety level required by the device category!



# Gardner Denver

## EU declaration of conformity

**Manufacturer:** Gardner Denver Deutschland GmbH  
Industriestraße 26, 97616 Bad Neustadt, Germany

**Representative for the compilation of technical documents:** Holger Krause  
Industriestraße 26, 97616 Bad Neustadt, Germany

**Designation of the machine:** Compressor/Vacuum Pump

Series	L-BV2 / L-BV5	
Types	2BV2060-..D..-Z	2BV2060-..G..-Z
	2BV2061-..D..-Z	
	2BV2070-..D..-Z	2BV2070-..G..-Z
	2BV2071-..D..-Z	2BV2071-..G..-Z
	2BV5110-..D..-Z	2BV5110-..G..-Z
	2BV5111-..D..-Z	
	2BV5121-..D..-Z	2BV5121-..G..-Z
	2BV5131-..D..-Z	
	2BV5161-..D..-Z	

**The manufacturer bears sole responsibility for issuing this declaration of compliance.**

**The machine described above complies with all applicable harmonisation legislation of the Community:**

**2006/42/EG** Directive 2006/42/EC of the European Parliament and of the Council of 17 May 2006 on machinery, and amending Directive 95/16/EC

**94/9/EC (to 19.04.2016)** Directive 94/9/EC of the European Parliament and the Council of 23 March 1994 on the approximation of the laws of the Member States concerning equipment and protective systems intended for use in potentially explosive atmospheres  
 **II 2G b c T3**

**2014/34/EU (from 20.04.2016)** Directive 2014/34/EU of the European Parliament and of the Council of 26 February 2014 on the harmonisation of the laws of the Member States relating to equipment and protective systems intended for use in potentially explosive atmospheres  
 **II 2G b c T3**

**harmonised standards and other technical specifications on which the declaration of compliance is based:**

**EN 1012-1:2010** Compressors and vacuum pumps - Safety requirements - Part 1: Compressors

**EN 1012-2:1996 +A1:2009** Compressors and vacuum pumps - Safety requirements - Part 2: Vacuum pumps

**EN ISO 12100:2010** Safety of machinery - General principles for design - Risk assessment and risk reduction (ISO 12100:2010)

**EN 1127-1: 2011** Explosive atmospheres - Explosion and protection - Part 1: Basic concepts and methodology

**EN 13463-1: 2009** Non-electrical equipment for potentially explosive atmospheres - Part 1: Basic method and requirements

**EN 13463-5: 2011** Non-electrical equipment for potentially explosive atmospheres - Part 5: Protection by constructional safety „c“

**EN 13463-6: 2005** Non-electrical equipment for potentially explosive atmospheres - Part 6: Protection by control of ignition source "b"

**The notified body DEKRA EXAM Gambol, no. 0158 has stored the technical documentation and has issued the following certification: BVS 03 ATEX H/B 072/ BVS 03 ATEX H/B 073**

Signed for and on behalf of: Gardner Denver Deutschland GmbH

Bad Neustadt, 11.01.2016

(Place and date of issue)



Andreas Bernklau, Product management/Authorised signatory  
(Name and function)

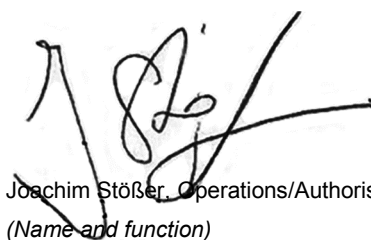

Joachim Stößer, Operations/Authorised signatory  
(Name and function)

664.44440.40.200



[www.gd-elmorietschle.de](http://www.gd-elmorietschle.de)  
[er.de@gardnerdenver.com](mailto:er.de@gardnerdenver.com)

---

**Gardner Denver**  
**Deutschland GmbH**  
Industriestraße 26  
97616 Bad Neustadt · Deutschland  
Tel. +49 9771 6888-0  
Fax +49 9771 6888-4000

Elmo Rietschle is a brand of Gardner Denver

**Gardner**  
**Denver**

Your Ultimate Source for Vacuum and Pressure